



Design of library noise detection tools based on voice pressure parameters

Yuda Irawan^{a,1,*}; Refni Wahyuni^{a,2}; Hasnor Khotimah^{a,3}; Herianto^{a,4}; Bambang Kurniawan^{a,5}; Haris Tri Saputra^{a,6}; Yulisman^{a,7}; Abdi Muhaimin^{a,8}; Reno Renaldi^{a,9}; Rahmaddeni^{b,10};

^a Universitas Hang Tuah Pekanbaru, Jln. Purwodadi Indah Km 10 Panam, Pekanbaru and 28294, Indonesia

^b STMIK Amik Riau, Jln. Mustafa Sari No 5, Pekanbaru and 28288, Indonesia

¹ yudairawan89@gmail.com; ² refniabid@gmail.com; ³ hasnorkhotimah.98@gmail.com; ⁴ herianto.sy@gmail.com; ⁵ ibenk.psht@gmail.com;

⁶ hariezalena@gmail.com; ⁷ yulisman@htp.ac.id; ⁸ abdi.muhamin86@gmail.com; ⁹ renorenaldi03@gmail.com; ¹⁰ rahmaddeni@sar.ac.id

* Corresponding author

Article history: Received June 03, 2022; Revised July 13, 2022; Accepted November 29, 2022; Available online December 20, 2022

Abstract

A library visitor would want a quiet atmosphere without noise when in the library so that he can concentrate when reading a book. However, not all visitors come to the library to read books; some want to chat and use free Wi-Fi or other, so it disturbs the concentration of other visitors who read books. Therefore, it is necessary to have a tool to detect sound pressure or sound based on the sound level and the sound produced in a library based on the noise level limit in the library, namely 45-55 dB (desible). This tool is designed based on a microcontroller where the definition of a microcontroller is a complete microprocessor system contained in a microcontroller chip which is different from the multi-purpose microprocessor used in a PC because a microcontroller generally already includes the minimum system supporting components of a microprocessor, namely memory, and programming. This tool can help officers monitor the library room for noise that can interfere with the concentration and comfort of library visitors. Based on the results of testing, the overall system is as desired, including the noise detection tool can work in an integrated system, where when the sound sensor detects a noise that exceeds the sound limit, the buzzer will sound, the red led light turns on, the sound module issues a voice message pre-recorded and also the device can be controlled or monitored from the web application.

Keywords: Noise Detection; Library; Voice Pressure Parameters; Nodemcu Esp8266

Introduction

Noise is unwanted sound or sound that comes from human activities that can cause health problems and comfort in the environment [1]. Based on its effect on humans, noise can be divided into three types: disturbing noise, obscuring noise, and destructive noise. The noise limit on the library is 45-55 dB (desible)[2].

Libraries are institutions that manage collections of written, printed, and recorded works professionally with a standard system to meet the needs of education, research, preservation, information, and recreation for visitors[3]. The library is a reading or study place that requires quietness and is away from noise[4]. Noise in a reading or study room can cause a loss of concentration, so activities in the library can be disturbed by noise caused by certain sounds, for example, the sound of a cellphone ringing sound produced by humans[5]. In addition, it can reduce the library users' effectiveness [6].

A library visitor would want a calm atmosphere without noise when in the library so that he can concentrate when reading a book[3]. However, not all visitors come to the library to read books. Some visitors just want to chat and use free Wi-Fi, so it disturbs the concentration of other visitors who come to read books[7][8]. Therefore, it is necessary to have a tool to detect sound pressure or sound based on the sound level and the sound produced in a library based on the noise level limit in the library, namely 45-55 dB (desible)[2],[9].

This tool is designed based on a microcontroller. A microcontroller is a complete microprocessor system contained in a microcontroller chip different from the multi-purpose microprocessor used in a PC[10][11]. This is because a microcontroller generally already has a minimal microprocessor system's supporting components, including memory and Input-Output programming[12].n Arduino is an open-source single-board microcontroller derived from the Wiring platform, designed to facilitate electronic use in various fields[13].

With the problems described above, the author will build a sound pressure detector in the library using NodeMCU ESP2866[14]. This tool uses a sound sensor to change the amount of sound into electrical quantities. This tool will work if the sound is detected. Then this tool will produce a warning output not to be noisy in the library in the form of a text display on the LCD and a warning sound through the sound module to alert visitors that the noise level in the library is starting to exceed the limit. This tool will also be equipped with an application that monitors and controls the tools in the library. Such as turning off the tool, turning it on, testing the sound, sound level information, and so on.

Arif Dwi Hidayat[15] has previously carried out the design of a noise detector as a final project to fulfill the graduation requirements, namely the design and manufacture of an automatic noise level detector using NodeMCU ESP8266. This tool can display the noise value based on the sound pressure level detected by the microphone. The tool can detect sound pressure levels in the range of 58 dB to 95 dB. This research still has shortcomings because no applications can complement the automatic noise detection tool. In this research, the noise detection tool in this library will be equipped with a Web-based application that can control and monitor the device's path.

Method

In this study, the authors used the Waterfall method because the waterfall method carried out the work of a system sequentially or linearly. This method is also a method that system researchers, in general, often use. Based on **Figure 1** the waterfall model is a waterfall method that provides a sequential or sequential approach to the software life flow, starting from analysis, design, coding, testing, and support.

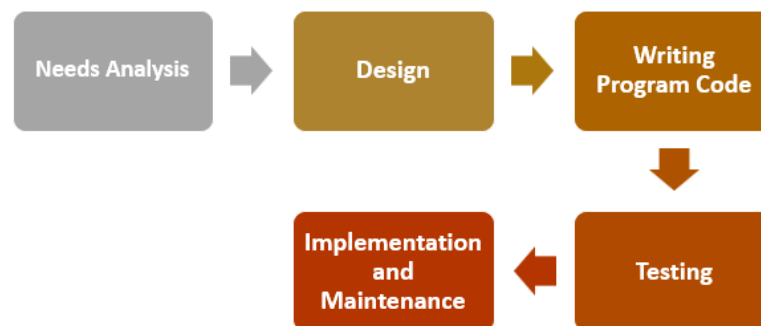

Figure 1. Waterfall Method

A. Needs Analysis

These needs include hardware and software. In this research, the selected hardware is NodeMCU ESP8266 because it is easy to operate, has a wifi device that can connect devices and networks, and uses the Arduino IDE as software in coding programs.

B. Design

Design is the stage of translating the needs analysis carried out in the previous stage into designing software and hardware that can be estimated first as a guide when building a system. At this stage, the writer will design a sketch image as a reference for building a library noise detection tool and its supporting applications.

C. Writing Program Code

At this stage, the researcher's needs will be translated into a programming language using the Arduino IDE software, which will be used with the C ++ programming language, after which the coding is entered into the NodeMCU ESP8266. Meanwhile, web-based supporting applications will use the PHP programming language.

D. Testing

After the coding stage is carried out, the next stage is testing the program to determine whether there are errors or not in the devices that have been built by using the C ++ programming language integrated with NodeMCU ESP8266.

E. Implementation and Maintenance

This stage is the final in making a system. After analyzing, designing, and coding, the finished tools will be applied to the library. Therefore, implementation and maintenance must be carried out to maintain stability, so unwanted things do not occur.

Results and Discussion

A. Hardware Design

Hardware design is a design or series of tools used to make Noise Detection tools.

a. Sound Sensor minimum system circuit

A sound Sensor is a sensor that changes the amount of sound into electrical quantities. This tool's working principle is similar to how touch sensors work on mobile phones, laptops, and notebooks. This series of sound sensors can be seen in the following **Figure 2**;

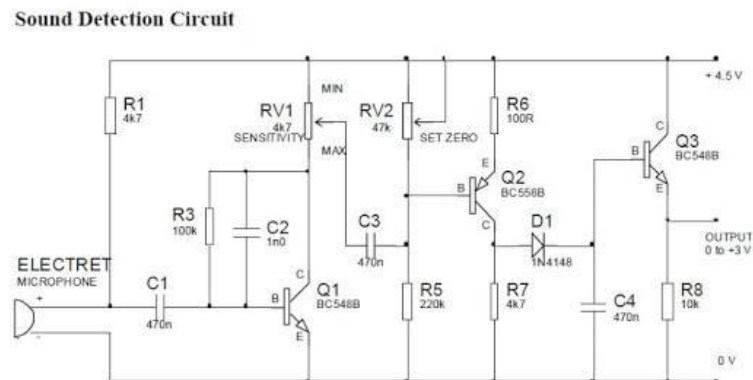

Figure 2. Sound sensor circuit schematic

b. NodeMCU Minimum System Circuit

NodeMCU is an open-source IoT platform and development kit that uses the Lua programming language to assist in making IoT product prototypes or can use sketch with the Arduino IDE. NodeMCU can also be used as a substitute for the function of Arduino because it is equipped with a function as a Microcontroller. The circuit can be seen in the following **Figure 3**;

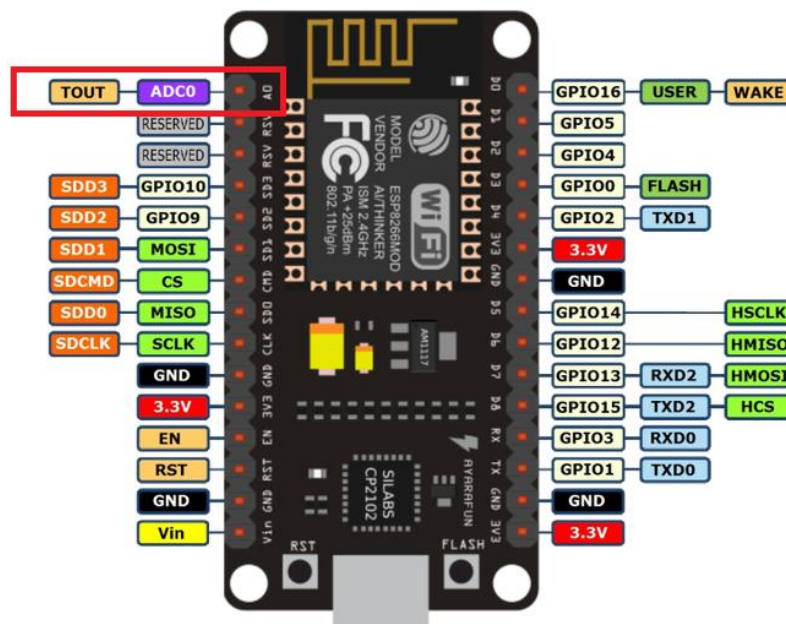

Figure 3. NodeMCU Circuit Schematic

c. ISD 1820 minimum system series

This ISD1820 module is a Sound Recording / Playback Module that can record and play back audio recordings with the integrated storage media (non-volatile memory) integrated into this single ISD1820 chip. Sound samples that can be recorded are between 8 to 20 seconds (can be one long sample / several short samples). The maximum recording length is determined based on the sound quality, which can be selected between 3.2 kHz (max 20 seconds) to 8 kHz (max 8 seconds). The sound module series can be seen in the Figure below:

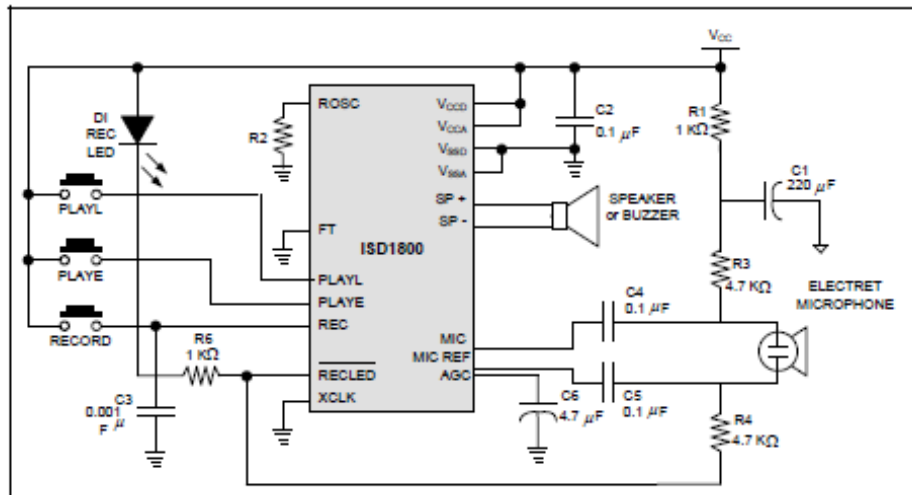

Figure 4. ISD 1820 Minimum System Series

Implementation is the stage of direct application of home security system tools. This stage is also part of a development. Implementation also determines the success rate of the project that has been built.

The implementation of Library Visitor Noise Detection Tool Based on Sound Pressure Parameters Using NodeMCU.



Figure 5. Display of Noise Detection Tool

The image above is a front and side view of the tool. In **Figure 5**, there are 3 indicator lights on the tool's upper side and a sound sensor section on the bottom side. **Figure 6** shows a part on the right side of the tool with a hole for the adapter connecting the tool to the electric current. **Figure 7** shows a blue indicator light that flashes every 2 seconds. An LCD also displays the device's IP and other menus that can be accessed. There are 2 red buttons in the middle on the right that function to access existing menus on the LCD, and the red button on the left is a test sound. Then at the bottom, there is a sound module that will issue a warning sound if there is excessive noise.



Figure 6. Shown in the Implementation of Noise Detection Tool



Figure 7. Display of the Webserver Monitor Tool Application

Image caption Implementation of Library Noise detection tools:

1. Plug the power cord of the library's noise detection tool into the electric current.
2. Wait until the device is connected to wifi.
3. After the library noise detection tool is connected to wifi and is turned on, the sound sensor will detect excessive noise in the library room.
4. If the sound sensor detects excessive noise in the library room, NodeMCU, as a microcontroller, will send a signal to the sound module, buzzer, and red led.
5. Then in the web application, officers can control the running of the noise detection device, such as viewing sound level information, testing sound, and turning off and turning on noise detection tools. Sound level information will be automatically updated once every 3 seconds.

System Testing

Testing the implementation of the library visitor noise detection tool using NodeMCU is as follows:

1. Connect the electric current to the power supply or adapter to control the electric power in the equipment circuit.
2. After that, the library noise detection tool will turn on with other supporting devices such as NodeMCU, sound sensor, sound module, buzzer etc.
3. Access the webserver application via IP which can be seen on the menu displayed on the LCD.

Testing Systems with Sound Sensors

This test is done by sounding the sound from the mobile device and the voice at a certain distance from the sound sensor to detect noise. There are 3 LED indicators to indicate how the sound levels are in the library room, Green LEDs (quiet), Yellow LEDs (a bit noisy), and Red LEDs (very noisy).

Table 1. Testing System with Microphone sound sensor KY-037

Distance (Meters)	Number of Tests	Detection	Response (Led)	Response Time (Seconds)
1	5 times	Yes	Red	1.38
2	5 times	Yes	Red	2.22
3	5 times	Yes	Red	3.69
4	5 times	Yes	Red	5.25
5	5 times	Yes	Yellow	10.27
6	5 times	No	Green	20.11
7	5 times	No	Green	30.50

Based on **Table 2** In the test contained in the table above, it is shown that the sound sensor will work up to a maximum distance of 6 meters with the slowest response time of 10.27 seconds, a yellow indicator light that states if the sound is a bit noisy.

B. Implementation Results

The results of the implementation of the system testing implementation of library visitor noise detection tools using NodeMCU, sound sensors, sound modules, buzzers are as follows **Table 2**:

Table 2. The implementation of the entire system test table.

Distance (Meters)	Number of Tests	Sound sensor	Sound Module	LED			Buzzer
				Red	Yellow	Green	
1	5 times	Detected	Beep	●	-	-	Beep
2	5 times	Detected	Beep	●	-	-	Beep

Distance (Meters)	Number of Tests	Sound sensor	Sound Module	LED			Buzzer
				Red	Yellow	Green	
3	5 times	Detected	Beep	●	-	-	Beep
4	5 times	Detected	Beep	●	-	-	Beep
5	5 times	Detected	No Sound	-	●	-	Beep
6	5 times	Not Detect	No Sound	-	-	●	No Sound
7	5 times	Not Detect	No Sound	-	-	●	No Sound

The limit for measurement is >40 db (noise) <50 . If this sound mic sensor receives an input (sound) at reasonable limits (> 40 db (noise) < 50 db), then the room will be declared "conductive." If it is still within limits, it will not interfere with the ear's hearing which can damage the ear. Meanwhile, if the sound mic sensor receives an input (sound) outside the normal range (>50 db), the room will be declared a "noisy room." It can cause hearing pain and can even damage hearing.

Conclusion

Some conclusions that can be drawn based on the results of the analysis, design, and implementation that have been carried out and based on the formulation of the existing problems are as follows; This tool can help officers in monitoring the library room from the noise that can disturb the concentration and comfort of library visitors. This tool is more effective if used in a library room with a smaller room scale, for example, a campus library or a library with a room-scale that is not too large. Based on the results of testing, the overall system is as desired. Namely, the noise detection tool can work in an integrated system, where the sound sensor detects a noise that exceeds the sound limit. The buzzer will sound, the red led light will turn on, the sound module issues a voice message pre-recorded, and the device can be controlled or monitored from the web application. The sound sensor test results shown in table 1 will work optimally if the noise comes from a human voice with a maximum distance of 6 meters. Meanwhile, if the sound comes from a mobile device such as a mobile phone with a distance of more than 3 meters, the sensitivity of this sensor is less.

Acknowledgment

The authors would like to thank Hang Tuah Pekanbaru University for willing to provide support in conducting this research.

References

- [1] J. Rajagukguk and N. E. Sari, "Detection system of Sound Noise Level (SNL) based on condenser microphone sensor," *J. Phys. Conf. Ser.*, vol. 970, no. 1, 2018, doi: 10.1088/1742-6596/970/1/012025.
- [2] S. R. U. . S. Theodorus S Kalengkongan, Dringhuzen J. Mamahit, "Rancang bangun alat deteksi kebisingan berbasis Arduino Uno," *J. Tek. Elektro dan Komput.*, vol. 7, no. 2, pp. 183–188, 2018.
- [3] G. Khan and R. Bhatti, "An analysis of collection development in the university libraries of Pakistan," *Collect. Build.*, vol. 35, no. 1, pp. 22–34, 2016, doi: 10.1108/CB-07-2015-0012.
- [4] L. Chapter, "A Happy Medium: Academic Library Noise from the Perspectives of Students and Librarians Elizabeth Layton and Mark Love, Nicholls State University," vol. 6, no. 1, pp. 32–53.
- [5] A. S. Aremu and A. A. Adedeji, "Assessing the noise pressure level in libraries ' Study Rooms in Nigeria – A Tropical Region," no. November 2015, 2012.
- [6] Nurwati, "Pendeteksi tingkat kebisingan dan pemberi peringatan pada perpustakaan berbasis arduino," *Semin. Nas. R.*, vol. 1, no. 1, pp. 1–4, 2018.

-
- [7] K. F. A. Widyadana, "Perancangan sistem kebisingan suara dengan sound sensor mic berbasis arduino," *Researchgate.Net*, no. April, 2021, [Online]. Available: https://www.researchgate.net/profile/Raditya-Pratama-6/publication/351153535_Perancangan_Sistem_Kebisingan_Suara_Dengan_Sound_Sensor_Mic_Berbasis_Arduino/links/608a9aac92851c490fa3ede2/PERANCANGAN-SISTEM-KEBISINGAN-SUARA-DENGAN-SOUND-SENSOR-MIC-BERBASIS-A.
- [8] S. Amarta, A. G. Putrada, and ..., "Asesmen kebisingan di open library Telkom University menggunakan sistem monitoring suara berbasis Iot," *eProceedings ...*, vol. 6, no. 1, pp. 2057–2064, 2019, [Online]. Available: <https://openlibrarypublications.telkomuniversity.ac.id/index.php/engineering/article/view/8489>.
- [9] A. A. Jaber and R. Bicker, "Real-Time wavelet analysis of a vibration signal based on arduino-UNO and LabVIEW," *Int. J. Mater. Sci. Eng.*, no. January 2015, pp. 66–70, 2015, doi: 10.12720/ijmse.3.1.66-70.
- [10] Y. A. Badamasi, "The working principle of an Arduino," *Proc. 11th Int. Conf. Electron. Comput. Comput. ICECCO 2014*, 2014, doi: 10.1109/ICECCO.2014.6997578.
- [11] I. I. M. Abu Sulayman, S. H. A. Almalki, and M. S. Soliman, "Design and implementation of a reliable wireless real-time home automation system based on Arduino Uno single-board microcontroller," *Prog. Electromagn. Res. Symp.*, vol. 2015-January, no. January 2015, pp. 2760–2764, 2015.
- [12] M. Magdin, Š. Koprda, and L. Ferenczy, "Biometrics authentication of fingerprint with using fingerprint reader and microcontroller Arduino," *Telkomnika (Telecommunication Comput. Electron. Control.*, vol. 16, no. 2, pp. 755–765, 2018, doi: 10.12928/TELKOMNIKA.v16i2.7572.
- [13] L. M. Herger and M. Bodarky, "Engaging students with open source technologies and Arduino," *ISEC 2015 - 5th IEEE Integr. STEM Educ. Conf.*, pp. 27–32, 2015, doi: 10.1109/ISECon.2015.7119938.
- [14] Y. Parihar, "Internet of Things and Nodemcu: A review of use of Nodemcu ESP8266 in IoT products," *J. Emerg. Technol. Innov. Res.*, vol. 6, no. 6, pp. 1085–1086, 2019, [Online]. Available: https://www.researchgate.net/profile/Yogendra-Singh-Parihar/publication/337656615_Internet_of_Things_and_Nodemcu_A_review_of_use_of_Nodemcu_ESP8266_in_IoT_products/links/5e29767b4585150ee77b868a/Internet-of-Things-and-Nodemcu-A-review-of-use-of-Nodemcu-ES.
- [15] A. D. Hidayat, B. Sudibya, and C. B. Waluyo, "Pendeteksi Tingkat kebisingan berbasis internet of things sebagai media kontrol kenyamanan ruangan perpustakaan," *Avitec*, vol. 1, no. 1, pp. 99–109, 2019, doi: 10.28989/avitec.v1i1.497.
-